

RV-M21 Tech Series

M21 UHF, VHF, 220MHz Band
500mW-5W Radio Modem

The RV-M21 Radio Modem is a rugged, modular data radio modem available in UHF, VHF & 220MHz bands. With its field-configurable I/O interface, the M21 can be configured for RS-232, RS-422, RS485, USB, GPIO, FIO or Audio interfaces in the lab or in the field as needed. It is over-the-air compatible with Raveon's 5-watt RV-M7 series of data radios.



Product Overview

Reconfigurable I/O

The front interface of the M21 is fully field-reconfigurable. The following interface boards may be attached or changed at any time:

- RS-232 [S] 5A835
- USB [U] 5A837
- RS-485 [T] 5A836-1
- RS-422 [F] 5A836-2
- GPIO [G] 5A833
- Analog [A] 5A838
- FIO [D] 5A832

Embedded M8 Modem

The M21 embeds within the enclosure an RV-M8 wireless modem. Any RV-M8 series modem may be inserted into the M21 chassis, giving the M21 all the benefits and features available in the M8 series of modems. M8 series modems can communicate with Raveon's M7 series modems.

Efficient Power Consumption

The RV-M21 can operate off DC input from 9-28V. Receiving, the M21 draws less than 1watt of power!

Long-Range Operation

The M21 radio modem works over 10 miles point-to-point and many miles with omni-directional antennas. All RV-M21 modems support store-and-forward repeating for wide-area coverage.

Fast Polling

The M21 transceiver has a 3mS PLL in it, making it one of the fastest telemetry radios available, especially well-suited for polled, DNP, and MODBUS applications.

High Speed and High Efficiency

The RV-M21 operates with user-selectable over-the air data rates from 1200 to 19200bps. Faster rates for higher efficiency or lower speed for increased communication range. This fast-switching radio can send 50 transmissions per second.

Secure Data

The data encryption feature may be enabled on any Tech Series data radio modem. When secure data is enabled, the M21 will encrypt transmissions using AES128 encryption. When properly managed your wireless network of Tech Series radio modems will be secure and hacker-proof.

GPS Option

The optional internal GPS allows the RV-M21 to be a powerful Automatic Vehicle Locating (AVL) system or Time Space Position Information (TSPI) reporting device. Global Navigation Satellite Systems (GNSS) systems and can receive GPS, GALILEO, or GLONASS on versions since G11. Monitor Speeds 0-1800 KM/H.

OTA Configuration

The ID of a particular transponder and certain system parameters such as report rate may be configured Over-The-Air, without having to physically connect to the unit.

Real-time diagnostics and statistics

Channel performance, RSSI, RF power, packet counters, and radio configuration are easily accessed via the serial port or remotely over-the-air

Flexible Addressing and Error Correction

The RV-M21 uses a 16 bit address with a 16 bit network mask, allowing for many devices to be co-located without receiving each other, providing for the creation of sophisticated network

topologies.



General Specifications

Model: RV-M21AB-CC-W

(A = I/O option) (B = G for GPS/GNSS option)
 (CC = frequency band code – see module datasheet)
 (W = W,N,Q, If a Bandwidth code exists, the radio is limited to the BW specified by the BW code)

Case Size:

5.75" X 2.75" X .90"

Weight:

12 oz

Input Voltage VCC:

12-28 VDC full-spec
 9-28 VDC operational

Power Consumption:

Receiving data: <100 mA at 12.0 VDC Input
 Transmitting data: < 2000 mA at 12.0 VDC Input
 Sleep (<100 µA)

Frequency Bands: {Internal Modem Number}

UA	400-434 MHz (non-US/gov.) {RV-M8}
UB	419-450 MHz (non-US/gov.) {RV-M8}
UC	450-470 MHz (RV-M8)
UD	480-512 MHz (non-US/gov.) {RV-M8}
UJ	380-400 MHz (non-US/gov.) {RV-M8}
VA	132-155 MHz (non-US/gov.) {RV-M8}
VB	150-174 MHz {RV-M8}
VC	216-222 MHz {RV-M8}

Serial Port Baud Rates (programmable)

1.2k, 2.4k, 4.8k, 9.6k, 19.2k, 38.4k, 57.6k, 115.2k

Over-the-air baud rates (programmable)

-N 1200, 2000, 2400, 4.8k, 5142, 8K,9.6k
 -W 1200, 2000, 2400, 4.8k, 8k, 9.6k

Full Spec Operating Temperature range

-30°C to +60°C

TX-RX and RX-TX turn-around time

<3mS

RF I/O Connector

BNC (Female), TNC (Female) optional

Addressing

Individual address: 65,536

Options:

Internal GPS, TDMA firmware G option

Security

Encryption Method..... AES128
 Electronic Serial Number..... Silicon ESN
 Configuration Monitor..... Serialized on update

Transmitter Specifications (See RV-M8 for details)

See the Datasheet of the Radio Module Used within the M21 enclosure for the Version you have. Here is a summary of Typical Specs:

RF Power Output VHF 500mW – 5W (programmable)
 RF Power Output UHF 500mW – 5W (programmable)
 Maximum Duty Cycle 100% to 40C, 20% to 60C
 Frequency Deviation ± 2.2kHz (-N) ± 3.5kHz (-W)
 Occupied bandwidth 11 kHz (-N) 16kHz(-W)
 TX Spurious outputs < -70dBc
 Occupied Bandwidth Per FCC
 FCC Emissions Designator..... 11K0F1D (-N)
 Frequency Stability..... Better than ±1.5ppm

Receiver Specifications (See RV-M8 for details)

See the Datasheet of the Radio Module used within the M21 enclosure for the Version you have. Here is a summary of Typical Specs:

RX sensitivity (.1% BER)	9600bps < -108dBm
	4800bps < -114dBm
1200 & 2400baud	< -118dBm
Adjacent Channel Selectivity 12.5kHz.....	-50dB
Adjacent Channel Selectivity 25kHz.....	-60dB
Alternate Channel Selectivity	-65dB
Blocking and spurious rejection	-75dB
RX intermodulation rejection.....	-70dB

Interface Option Connections

RS-232 Interface Port

Connector Type	DB-9 female
IO Voltage Levels	RS-232

RS-485 Interface Port

Connector Type	Phoenix 6-pin
IO Voltage Levels	RS-485

USB Interface Port

Connector Type	Mini B
----------------	--------

Analog Interface Port

Connector Type	DB-15 female
----------------	--------------

GPIO Interface Port

Connector Type	Phoenix 6-pin
----------------	---------------

FIO Interface Port

Connector Type	DB-15 female
IO Voltage Levels	TTL 0-3.3V

Raveon Technologies Corporation

1963 Avenida Plaza Real
 Oceanside CA 92056 - USA
 Phone: +1-760-444-5995

Email: sales@raveon.com

Feb 2026
 All rights reserved
 Version H10

Input/Output Connection Functions

RS-232 Interface Port

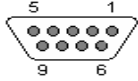

1	CD	Carrier detect
2	RxD	Receive data
3	TxD	Transmit data
4	DTR	Data terminal ready
5	GND	Ground connection
6	DSR	Data Set Ready
7	RTS	Request to send
8	CTS	Clear to send
9	Power	DC power (not Ring signal)

Analog Interface Port

1	MIC	Analog Input
2	AUX	Analog Output
3	TDX	TX data In, RS232
4	RSSI	Radio Signal Strength Out
5	DTR	Digital DTR out
6	VIN	DC Voltage Input
7	V3	3./3V Output
8	IOC	General IO - C
9	RXD	RX data out, RS232 level
10	CTS	CTS, 3V digital level
11	NC	No connect
12	PTT	Transmitter Enable Line
13	NC	No connect
14	DCD	Data/Carrier Detect output
15	GND	Ground, chassis and power gnd.

T RS-485 Interface Port

1	RTS	RTS Input
2	RXDP	RX Data, +
3	RXDM	RX Data, -
4	TXDP	TX Data, +
5	TXDM	TX Data, -
6	GND	Ground, chassis and power gnd.

F RS-422 Interface Port

1	MODE	Mode Input
2	Y	RX Data, +
3	Z	RX Data, -
4	A	TX Data, +
5	B	TX Data, -
6	GND	Ground, chassis and power gnd.

GPIO Interface Port



1	RDX	RX data out, RS232 level
2	TXD	TX data In, RS232
3	IO0	Configurable General Purpose IO*

4	IO1	Configurable General Purpose IO
5	IO2	Configurable General Purpose IO
6	GND	Ground, chassis and power gnd.

IOs can be configured as: A: Digital TTL Input, C: Open Drain MOSFET output, D: DC Power switch output. E :Analog Input.
*IO1 cannot be switched DC

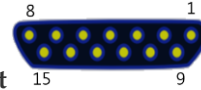

FIO Interface Port

1	VIN	DC Voltage Input
2	TXD	TX data In, RS232
3	OD0	Open drain output, switched
4	IO0	Configurable General Purpose IO
12	IO1	Configurable General Purpose IO
5	IO2	Configurable General Purpose IO
13	IO3	Configurable General Purpose IO
6	IO4	Configurable General Purpose IO
14	IO5	Configurable General Purpose IO
7	IO6	Configurable General Purpose IO
15	IO7	Configurable General Purpose IO
9	VDIG	Voltage out, Digital voltage as configured internal to RV-M21.
8,11	GND	Ground connection

IOs can be configured as: A:Digital TTL Input, B:Digital TTL Output.

Accessories

DC Power Cable

Raveon part number	4C850-1
Description	M8, Sealed 3-pin 7mm, 2m

Raveon Technologies Corporation

1963 Avenida Plaza Real
Oceanside CA 92056 - USA
Phone: +1-760-444-5995

Email: sales@raveon.com

Feb 2026
All rights reserved

Version H10

Example: RV-M21SG-UCN RS232 I/O, 450-470MHz, narrow-band, with GPS transponder option.

	RV-M22	IO Code	GPS Code	-	BAND Code	Band Width	-	Other Options
	CODE							
RS232	S							
RS422	F							
RS485	T							
USB	U							
Analog	A							
FIO	F							
GPIO	G							
No GPS								
GPS Option	G							
No Radio Board	X							
132-150MHz	VA							
150-174MHz	VB							
216-222MHz	VC							
400-434MHz	UA							
430-450MHz	UB							
450-480MHz	UC							
12.5kHz chan.	N							
25kHz chan.	W							
Arduino CPU	A							

Raveon Technologies Corporation

1963 Avenida Plaza Real
 Oceanside CA 92056 - USA
 Phone: +1-760-444-5995

Email: sales@raveon.com

Feb 2026
 All rights reserved
 Version H10

FIO and GPIO IO Specifications

FIO Digital Input Specifications:

Low-level input voltage: Less than 0.5V
 High-level input voltage: Greater than 2.2V
 Input resistance: Floating, > 2K resistance.

FIO Digital Output Specifications:

Low-level Output voltage: Less than 0.5V
 High Level Output Voltage: 3.0 - 3.3V
 Output resistance: 330 ohms.

GPIO Digital Input Specifications:

Low-level input voltage: Less than 0.5V
 High-level input voltage: Greater than 2.2V
 Input resistance: 5K-10K pull-down resistance.

GPIO Digital Output Specifications:

Low-level Output voltage: Less than 0.5V
 High Level Output Voltage: 3.0 - 3.3V
 Output resistance: 250 ohms

GPIO Open Drain Output Specifications:

Low-level Output voltage, on: 0V to 0.5V drawing less than 2.1A.
 Open drain off leakage resistance 500uA, 0-5V, < 1mA 5-20V
 High Level Output Voltage, off: 0 - 20V < VCC input volts
 Output resistance, on: <250 milliohms to ground

GPIO Switched DC power output: (IO1 and IO2) not IO0.

Output voltage, on: Same as DC input, 90%-100%.
 Maximum Output Current 1.0 amps
 Output resistance, on: <250 milliohms to ground
 On state internal resistance 100-250mOhms.
 Maximum volt input when off DC input + 150mV
 Off output off leakage resistance 5-200uA
 High Level Output Voltage, off: Same limit as RF board within the enclosure.

GPIO Analog Input Specifications:

Low-level input voltage: 0V
 High-level input voltage: V in - 1.0V. V in is the DC power voltage. 0-30V is typical.
 Input resistance: 220K.

If other FIO or GGPIO interface requirements are needed, please contact Raveon's Customer support and give us information about your IO requirements, and we can set them up for you.

Mechanical Specifications

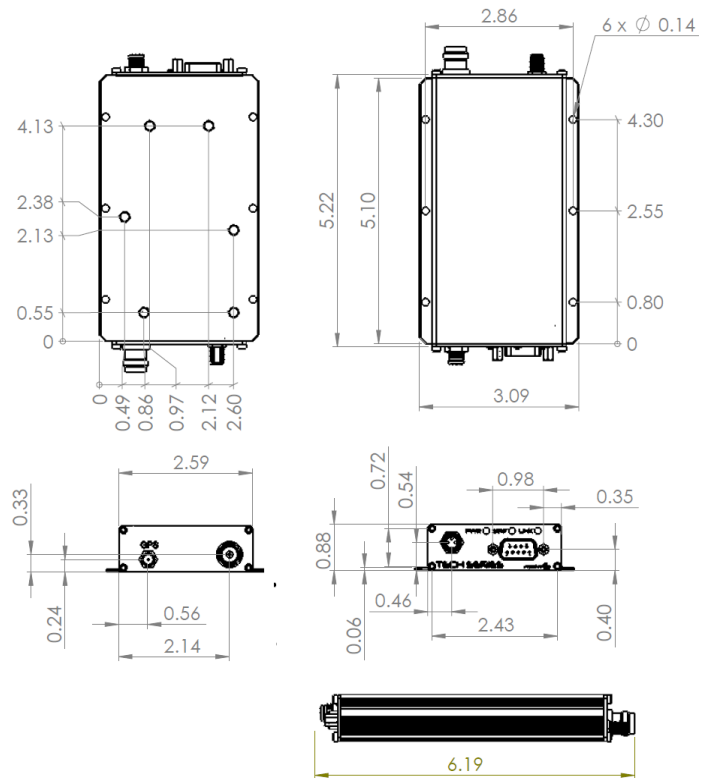

Raveon Technologies Corporation

1963 Avenida Plaza Real
 Oceanside CA 92056 - USA
 Phone: +1-760-444-5995

Email: sales@raveon.com

Feb 2026
 All rights reserved
 Version H10